

# AM3189 – Filter

## 9 GHz to 10 GHz Bandpass Filter

### Description

AM3189 is a passive bandpass filter implemented on chip that provides low loss and high rejection in a small 4 mm package. With a center frequency of 9.5 GHz and a bandwidth of 1 GHz, AM3189 is useful as an IF filter in any RF system for image, LO, and spur rejection. AM3189 is AC coupled and matched to 50 ohms while operating over the -40C to +100C temperature range.

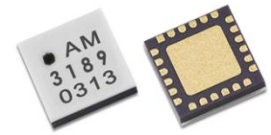

### Features

- 9.5 GHz Center Frequency
- 1 GHz Bandwidth
- 0.3 dB Passband Flatness Typical
- >40 dB Stopband Rejection
- 0.5 W Power Handling
- 4mm QFN Package
- -40C to +100C Operation

### Functional Diagram

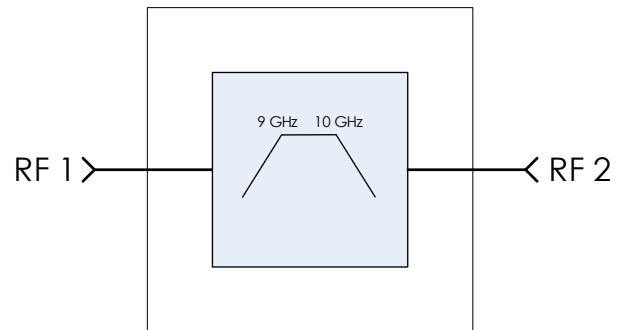

### Characteristic Performance

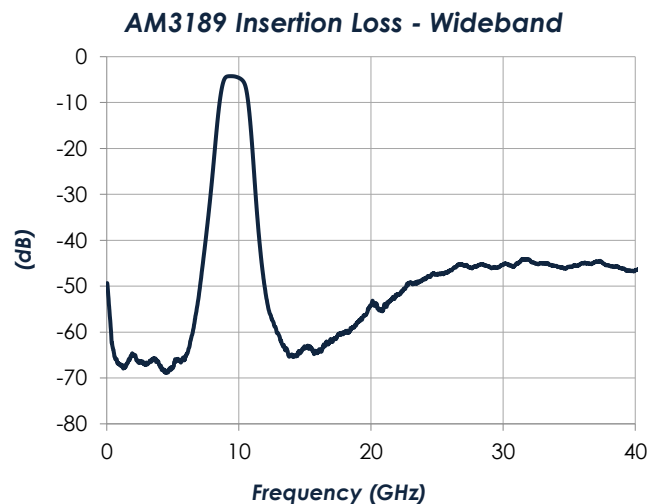
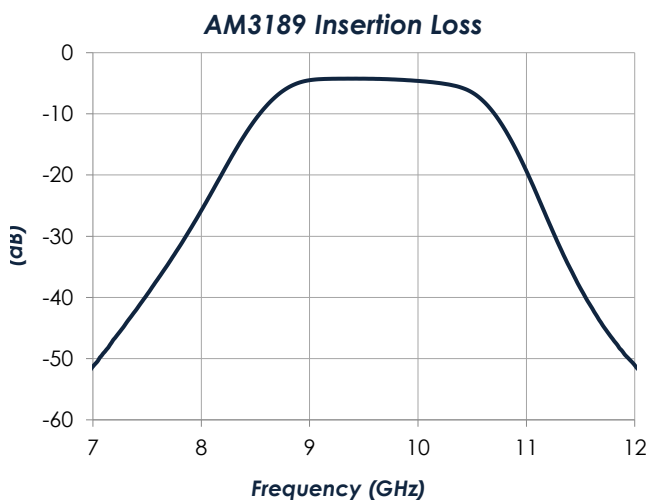

### Table of Contents

<b>Description</b> .....	1	Recommended Operating Conditions ...	4
<b>Features</b> .....	1	RF Performance .....	4
<b>Functional Diagram</b> .....	1	Typical Performance .....	5
<b>Characteristic Performance</b> .....	1	<b>Typical Application</b> .....	3
<b>Revision History</b> .....	2	<b>Evaluation PC Board</b> .....	6
<b>Pin Layout and Definitions</b> .....	3	<b>Part Ordering Details</b> .....	6
<b>Specifications</b> .....	4	<b>Related Parts</b> .....	6
Absolute Maximum Ratings .....	4	<b>Component Compliance Information</b> .....	7
Handling Information .....	4		

### Revision History

Date	Revision Number	Notes
June 22, 2021	1	Initial release

# AM3189 – Filter

9 GHz to 10 GHz Bandpass Filter

## Pin Layout and Definitions

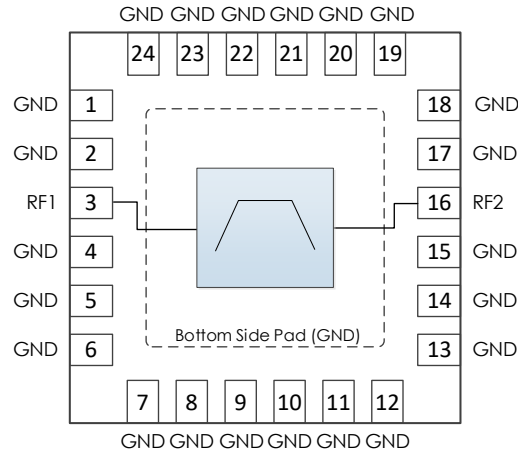

Pin Number	Pin Name	Pin Function
1-2	GND	Ground - Common
3	RF1	RF Port 1 – 50 ohms, AC coupled
4 – 15	GND	Ground – Common
16	RF2	RF Port 2 – 50 ohms, AC coupled
17 – 24	GND	Ground – Common

## Typical Application

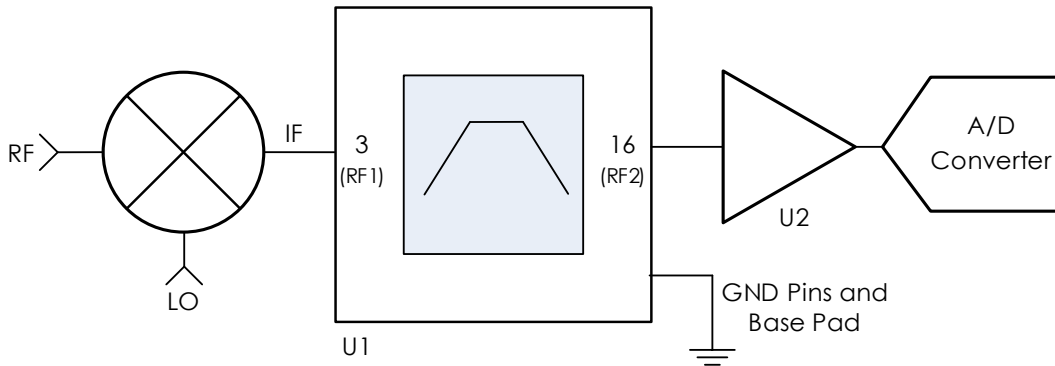

## Recommended Component List (or equivalent):

Part	Value	Part Number	Manufacturer
U1		AM3189	Atlanta Micro
U2		AM1082	Atlanta Micro

# AM3189 – Filter

## 9 GHz to 10 GHz Bandpass Filter



### Specifications

#### Absolute Maximum Ratings

	Minimum	Maximum
RF Input Power		+27 dBm
Operating Junction Temperature	-40 C	+150 C
Storage Temperature Range	-55 C	+150 C

**Note:** Any device operation beyond the Absolute Maximum Ratings may result in permanent damage to the device. The values listed in this table are extremes and do not imply functional operation of the device at these or any other conditions beyond what is listed under Recommended Operating Conditions. Any part subjected to conditions outside of what is recommended for an extended amount of time may suffer from reliability concerns.

#### Handling Information

	Minimum	Maximum
Storage Temperature Range (Recommended)	-50 C	+125 C
Moisture Sensitivity Level	MSL 1	



Atlanta Micro products are electrostatic sensitive.  
Follow safe handling practices to avoid damage

#### Recommended Operating Conditions

	Minimum	Typical	Maximum
Operating Case Temperature	-40 C		+100 C
Operating Junction Temperature	-40 C		+125 C

#### RF Performance

(T = 25 °C unless otherwise specified)

Parameter	Testing Conditions	Minimum	Typical	Maximum
Passband Range		9 GHz		10 GHz
Bandwidth			1 GHz	
Passband Flatness			0.2 dB	
Stopband Rejection		35 dB		
Insertion Loss	f = 9.0 GHz		4.5 dB	
	f = 9.5 GHz		4.2 dB	
	f = 10.0 GHz		4.6 dB	
Return Loss	f = 9.0 GHz		23 dB	
	f = 9.5 GHz		20 dB	
	f = 10.0 GHz		17 dB	

# AM3189 – Filter

## 9 GHz to 10 GHz Bandpass Filter

### Typical Performance

(T = 25 °C unless otherwise specified. Refer to s-parameters available for download on Atlanta Micro website for more information)

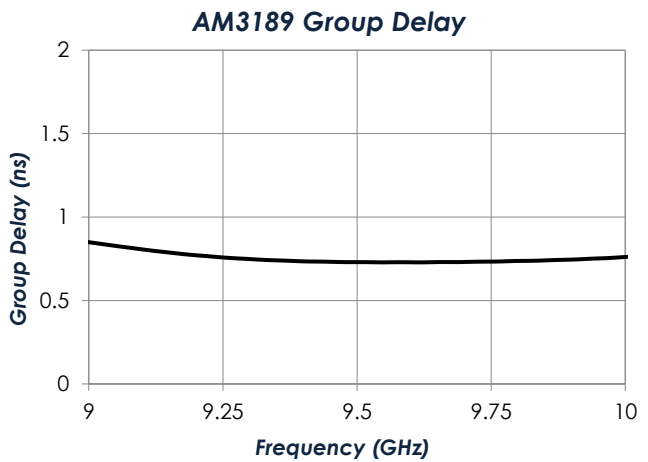
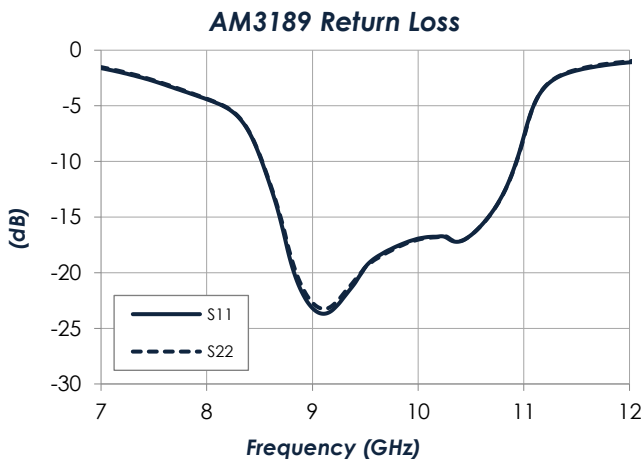
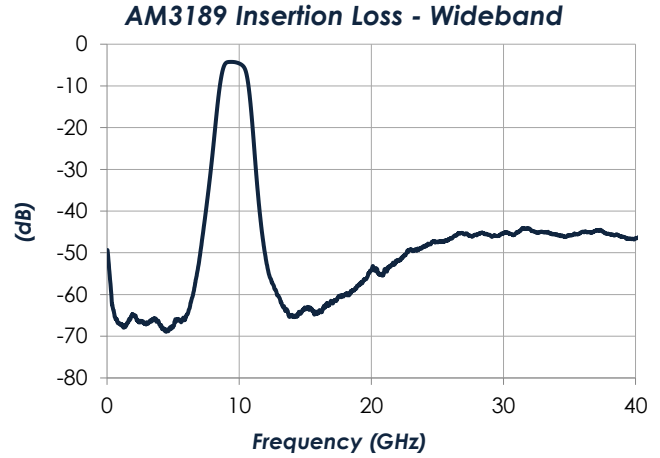
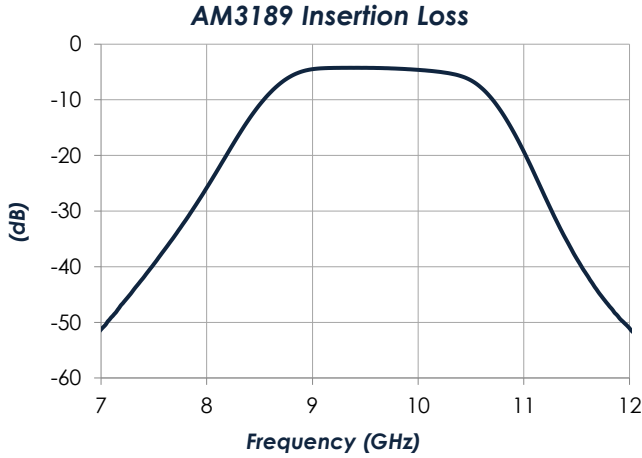

v

# AM3189 – Filter

9 GHz to 10 GHz Bandpass Filter



## Evaluation PC Board

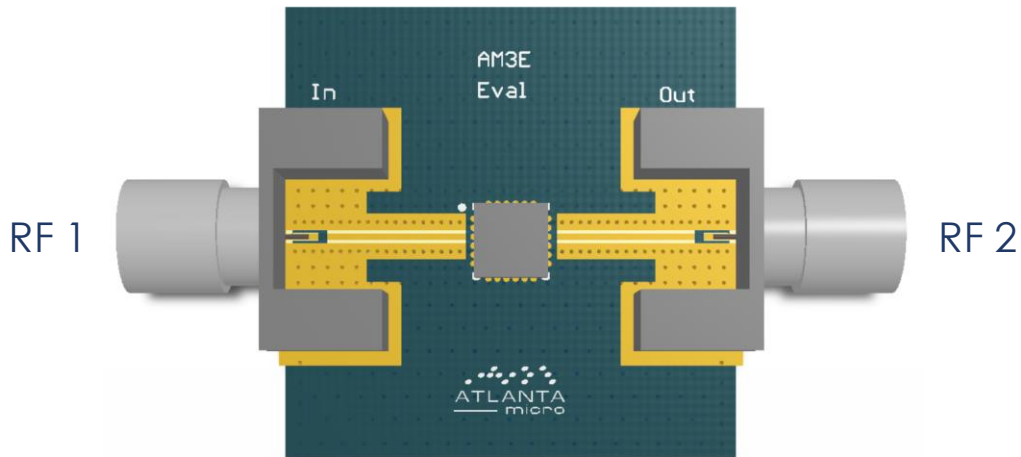

## Part Ordering Details

Description	Part Number
4mm x 4mm x 0.9mm QFN package	AM3189
AM3189 with Connectorized Evaluation Board	AM3189 Eval

## Related Parts

Part Number	Description
AM1082	5 GHz to 17 GHz Amplifier
AM3056	750 MHz to 1250 MHz Bandpass Filter
AM3055	1.5 GHz to 2.5 GHz Bandpass Filter
AM3188	2.5 GHz to 3.5 GHz Bandpass Filter
AM3187	3.25 GHz to 4.25 GHz Bandpass Filter
AM3134	2 GHz to 4.5 GHz Dual Analog Tunable Bandpass
AM3104	2.5 GHz to 6.5 GHz Digitally Tunable Bandpass
AM3045	3 GHz to 6 GHz Digitally Tunable Bandpass

To obtain price, delivery, or to place an order contact [sales@atlantamicro.com](mailto:sales@atlantamicro.com)  
Atlanta Micro Inc., 3720 Davinci Ct, Suite 400, Peachtree Corners, GA 30092 • Phone: (470) 253-7640 • [www.atlantamicro.com](http://www.atlantamicro.com)

### Component Compliance Information

**RoHS:** Atlanta Micro, Inc. hereby certifies that all products comply with the EC Directive 2011/65/EC on the Restriction of Hazardous Substances, commonly known as EU-RoHS 6 and 10. All products supplied by Atlanta Micro shall be compliant with the European Directive 2011/65/EC based on the following substance list.

Substance List	Allowable Maximum Concentration
Lead (Pb)	<1000 PPM (0.1% by weight)
Mercury (Hg)	<1000 PPM (0.1% by weight)
Cadmium (Cd)	<75 PPM (0.0075% by weight)
Hexavalent Chromium (CrVI)	<1000 PPM (0.1% by weight)
Polybrominated Biphenyls (PBB)	<1000 PPM (0.1% by weight)
Polybrominated Diphenyl ethers (PBDE)	<1000 PPM (0.1% by weight)
Decabromodiphenyl Deca BDE	<1000 PPM (0.1% by weight)
Bis (2-ethylhexyl) Phthalate (DEHP)	<1000 PPM (0.1% by weight)
Butyl Benzyl Phthalate (BBP)	<1000 PPM (0.1% by weight)
Dibutyl Phthalate (DBP)	<1000 PPM (0.1% by weight)
Diisobutyl Phthalate (DIBP)	<1000 PPM (0.1% by weight)

**REACH:** Atlanta Micro, Inc. neither uses nor intentionally adds any of the substances considered to be a Substance of Very High Concern (SVHC) as defined by the EU Regulation (EC) No. 1907-2006 on Registration, Evaluation, Authorization, and Restriction of Chemicals (REACH).

**Conflict Materials:** Atlanta Micro does not knowingly use materials that are sourced from the Democratic Republic of Congo (DRC) or any other known conflict regions. Atlanta Micro's supply chain is comprised of sources that are both environmentally and socially responsible. We periodically review this requirement with our vendors to ensure continued compliance.

Atlanta Micro takes its responsibility as a global partner seriously and will use due diligence within our supply chain to ensure all standards are met to the best of our knowledge.