

AM3063 – Filter Bank

Digitally Tunable 6 to 18 GHz Bandpass

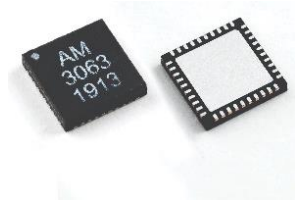

AM3063 is a miniature filter IC containing digitally tunable bandpass filters covering the 6.0 GHz to 18.0 GHz frequency range. Separate low-pass and high-pass control lines provide independent control of both center frequency and bandwidth. Power and Control lines are internally filtered using Mercury’s AM35 filter chip. AM3063 provides an excellent filtering solution for a receiver or transceiver requiring flexible center frequency and bandwidth, high dynamic range, and small size, weight, and power consumption.

FEATURES

- Digitally Tunable Bandpass Filters
- Independent LP and HP control
- +3.3V to +5.0V Supply
- 4.0 dB Insertion Loss
- Integrated Power and Control Line Filtering (See AM35 Datasheet)
- 6mm 40 lead QFN Package
- +40 dBm Input IP3
- -40C to +85C Operation

CHARACTERISTIC PERFORMANCE

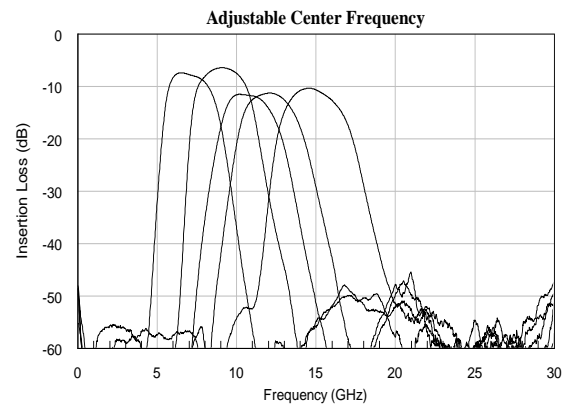

FUNCTIONAL DIAGRAM

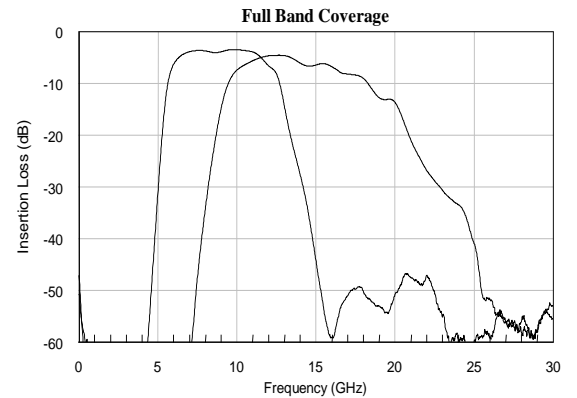
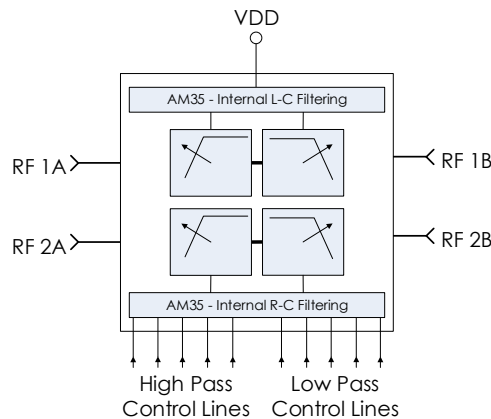

CONTENTS

FEATURES 1

FUNCTIONAL DIAGRAM 1

CHARACTERISTIC PERFORMANCE 1

REVISION HISTORY..... 2

PIN LAYOUT AND DEFINITIONS 3

SPECIFICATIONS..... 4

TYPICAL PERFORMANCE 6

TYPICAL APPLICATION..... 10

EVALUATION PC BOARD..... 11

RELATED PARTS 11

COMPONENT COMPLIANCE INFORMATION 12

REVISION HISTORY

Date	Revision	Notes
March 30, 2018	1	Preliminary Release.
May 9, 2018	2	Updated for new datasheet format.
August 17, 2018	3	Specifications Updated.
August 22, 2018	4	Various Pictures Updated.
January 15, 2019	5	Various Notes Updated.
March 14, 2019	6	Updated State Table.
July 17, 2019	7	Various Notes Added, Component Compliance Information Updated, Footprint Corrected.
June 26, 2024	8	Changed to Mercury branding. No content changes.

PIN LAYOUT AND DEFINITIONS

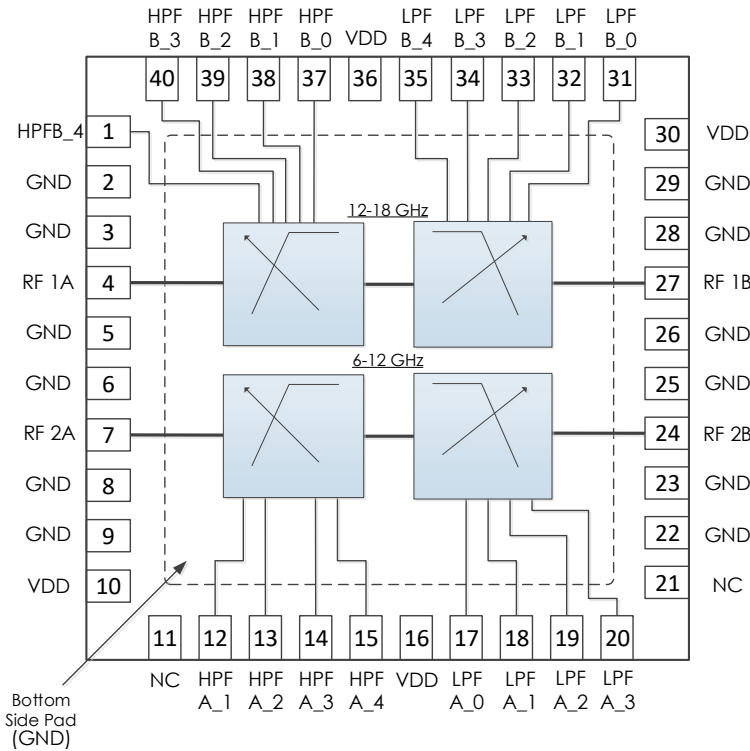

Pin	Name	Function
15	HPFA_4	6-12 GHz HPF control bit 4
16	VDD	DC Supply
17	LPFA_0	6-12 GHz LPF control bit 0
18	LPFA_1	6-12 GHz LPF control bit 1
19	LPFA_2	6-12 GHz LPF control bit 2
20	LPFA_3	6-12 GHz LPF control bit 3
21	LPFA_4	6-12 GHz HPF control bit 4 (reserved for future use)
22,23	GND	Ground - Common
24	RF2B	6-12 GHz RF Port B - 50 ohms - DC coupled - DC blocking capacitor required*
25,26	GND	Ground - Common
27	RF1B	12-18 GHz RF Port B - 50 ohms - DC coupled - DC blocking capacitor required*
28,29	GND	Ground - Common
30	VDD	DC Supply
31	LPFB_0	12-18 GHz LPF control bit 0
32	LPFB_1	12-18 GHz LPF control bit 1
33	LPFB_2	12-18 GHz LPF control bit 2
34	LPFB_3	12-18 GHz LPF control bit 3
35	LPFB_4	12-18 GHz LPF control bit 4
36	VDD	DC Supply
37	HPFB_0	12-18 GHz HPF control bit 0
38	HPFB_1	12-18 GHz HPF control bit 1
39	HPFB_2	12-18 GHz HPF control bit 2
40	HPFB_3	12-18 GHz HPF control bit 3
Case GND	GND	Ground - Common

Pin	Name	Function
1	HPFB_4	12-18 GHz HPF control bit 4
2,3	GND	Ground - Common
4	RF1A	12-18 GHz RF Port A - 50 ohms - DC coupled - DC blocking capacitor required*
5,6	GND	Ground - Common
7	RF2A	6-12 GHz RF Port A - 50 ohms - DC coupled - DC blocking capacitor required*
8,9	GND	Ground - Common
10	VDD	DC Supply
11	HPFA_0	6-12 GHz HPF control bit 0 (reserved for future use)
12	HPFA_1	6-12 GHz HPF control bit 1
13	HPFA_2	6-12 GHz HPF control bit 2
14	HPFA_3	6-12 GHz HPF control bit 3

*Note: DC blocking caps not required if in series with other Mercury parts of the same reference voltage.

SPECIFICATIONS

Absolute Maximum Ratings

	Minimum	Maximum
Supply Input Voltage	-0.3 V	+6.0 V
RF Input Power		+27 dBm
Operating Junction Temperature	-40 C	+150 C
Storage Temperature Range	-50 C	+150 C

Recommended Operating Conditions

	Minimum	Typical	Maximum
Supply Voltage	+2.7 V	+5.0 V	
Operating Case Temperature	-40 C		+85 C
Operating Junction Temperature	-40 C		+125 C

Note: Any device operation beyond the Absolute Maximum Ratings may result in permanent damage to the device. The values listed in this table are extremes and do not imply functional operation of the device at these or any other conditions beyond what is listed under Recommended Operating Conditions. Any part subjected to conditions outside of what is recommended for an extended amount of time may suffer from reliability concerns.

Handling Information

	Minimum	Maximum
Storage Temperature Range (Recommended)	-50 C	+125 C
Moisture Sensitivity Level	MSL 3	



Mercury products are electrostatic sensitive. Follow safe handling practices to avoid damage.

DC Electrical Characteristics

Param	Testing Conditions	Min	Typical	Max
DC Supply Voltage		+2.7 V	+5.0 V	
DC Supply Current	VDD = +5.0 V		2 mA	
Power Dissipated	VDD = +5.0 V		10 mW	
Logic Level Low		-0.1 V		+0.5 V
Logic Level High		+2.0 V		+VDD

*Power and Control lines are internally filtered. See AM35 datasheet for performance details.

RF Performance

Param	Testing Conditions	Min	Typical	Max
Frequency Range				18.0 GHz
Insertion Loss	f = 6.0 GHz		5.9 dB	
	f = 10.0 GHz		3.5 dB	
	f = 12.0 GHz		4.6 dB	
	f = 18.0 GHz		5.9 dB	
Return Loss	f = 6.0 GHz		27.0 dB	
	f = 10.0 GHz		17.5 dB	
	f = 12.0 GHz		25.6 dB	
	f = 18.0 GHz		12.86 dB	
Input IP3			+40 dBm	

Timing Characteristic

	Minimum	Typical	Maximum
Switching Speed			1 μ s

State Tables

6 - 12 GHz High Pass Control Lines					6 - 12 GHz Low Pass Control Lines				
A_4	A_3	A_2	A_1	Typical Cutoff Freq. (GHz)	A_3	A_2	A_1	A_0	Typical Cutoff Freq. (GHz)
L	L	L	L	6.00	L	L	L	L	6.00
L	L	L	H	6.05	L	L	L	H	6.05
L	L	H	L	6.15	L	L	H	L	6.15
L	L	H	H	6.20	L	L	H	H	6.20
L	H	L	L	6.35	L	H	L	L	6.35
L	H	L	H	6.40	L	H	L	H	6.40
L	H	H	L	6.60	L	H	H	L	6.60
L	H	H	H	6.70	L	H	H	H	6.70
H	L	L	L	6.75	H	L	L	L	6.75
H	L	L	H	6.90	H	L	L	H	6.90
H	L	H	L	7.30	H	L	H	L	7.30
H	L	H	H	7.40	H	L	H	H	7.40
H	H	L	L	7.90	H	H	L	L	7.90
H	H	L	H	8.35	H	H	L	H	8.35
H	H	H	L	8.90	H	H	H	L	8.90
H	H	H	H	9.50	H	H	H	H	9.50

STATE TABLES (CONTINUED)

12 - 18 High Pass Control Lines					Typical Cutoff Freq. (GHz)
B_4	B_3	B_2	B_1	B_0	
L	L	L	L	H	9.95
L	L	L	L	L	10.00
L	L	L	H	H	10.05
L	L	L	H	L	10.10
L	L	H	L	H	10.15
L	L	H	L	L	10.20
L	L	H	H	H	10.30
L	L	H	H	L	10.35
L	H	L	L	H	10.40
L	H	L	L	L	10.45
L	H	H	H	H	10.50
L	H	H	H	L	10.60
L	H	L	L	H	10.70
L	H	L	L	L	10.80
L	H	H	H	H	10.85
L	H	H	H	L	10.90
H	L		L	H	11.10
H	L		L	L	11.25
H	L		H	H	11.40
H	L		H	L	11.50
H	L		L	H	11.65
H	L		L	L	11.90
H	L		H	H	12.10
H	L		H	L	12.40
H	H		L	H	12.65
H	H		L	L	13.00
H	H		H	H	13.30
H	H		H	L	13.70
H	H		L	H	14.15
H	H		L	L	14.70
H	H		H	H	15.30
H	H		H	L	15.85

12 - 18 Low Pass Control Lines					Typical Cutoff Freq. (GHz)
B_4	B_3	B_2	B_1	B_0	
L	L	L	L	L	10.80
L	L	L	L	H	10.90
L	L	H	H	L	11.00
L	L	H	H	H	11.10
L	L	L	L	L	11.20
L	L	L	L	H	11.35
L	L	H	H	L	11.45
L	L	H	H	H	11.60
H	H	L	L	L	11.70
H	H	L	L	H	12.00
H	H	H	H	L	12.10
H	H	H	H	H	12.50
H	H	L	L	L	12.65
H	H	L	L	H	12.90
H	H	H	H	L	13.00
H	H	H	H	H	13.15
H	L	L	L	L	12.95
H	L	L	L	H	13.20
H	L	H	H	L	13.30
H	L	H	H	H	13.45
H	L	L	L	L	13.55
H	L	L	L	H	13.75
H	L	H	H	L	13.90
H	L	H	H	H	14.50
H	H	L	L	L	15.50
H	H	L	L	H	15.75
H	H	H	H	L	16.15
H	H	H	H	H	16.25
H	H	L	L	L	16.50
H	H	L	L	H	17.00
H	H	H	H	L	18.00
H	H	H	H	H	19.50

TYPICAL PERFORMANCE

*Note: Only some states shown for simplicity.

6.0 - 12.0 GHz

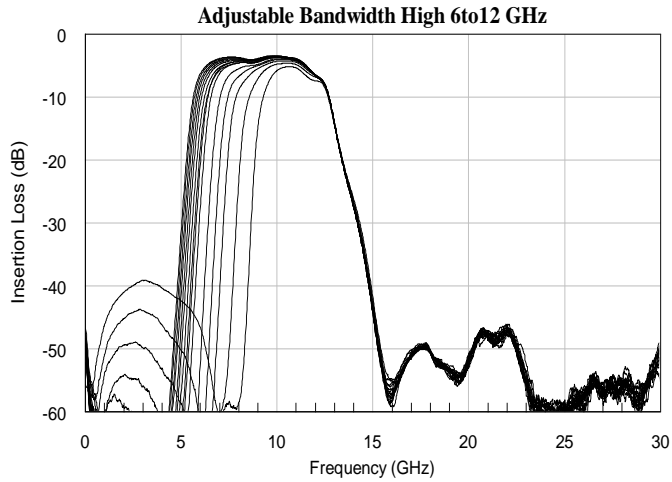

12.0 - 18.0 GHz

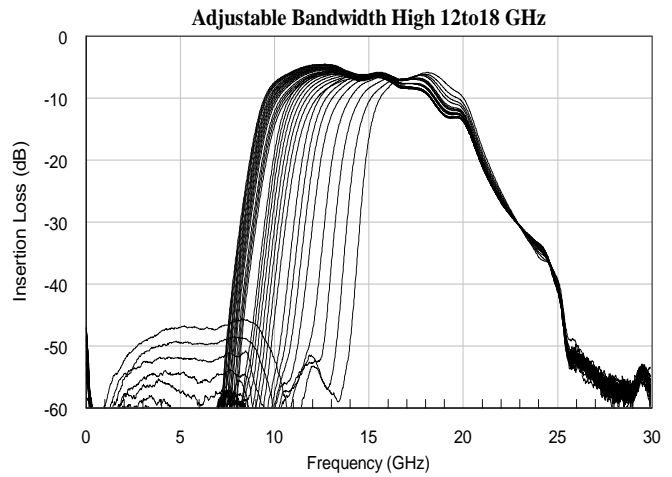

Adjustable Bandwidth Low 6to12 GHz

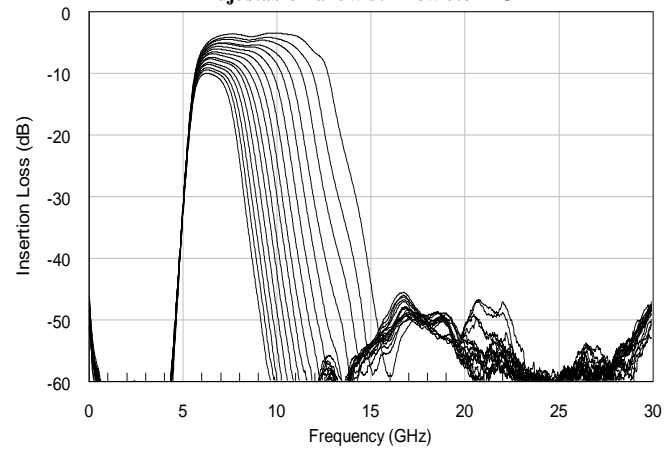

Adjustable Bandwidth Low 12to18 GHz

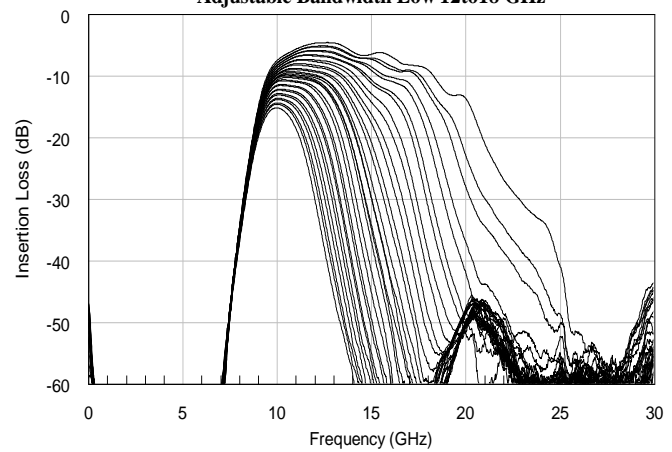

Adjustable Bandwidth Center 6to12 GHz

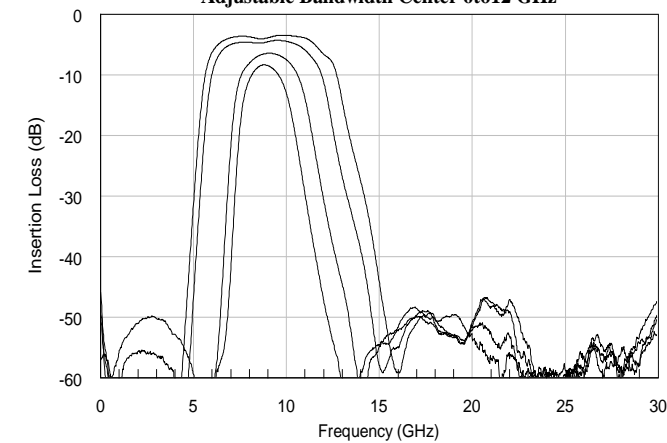

Adjustable Bandwidth Center 12to18 GHz

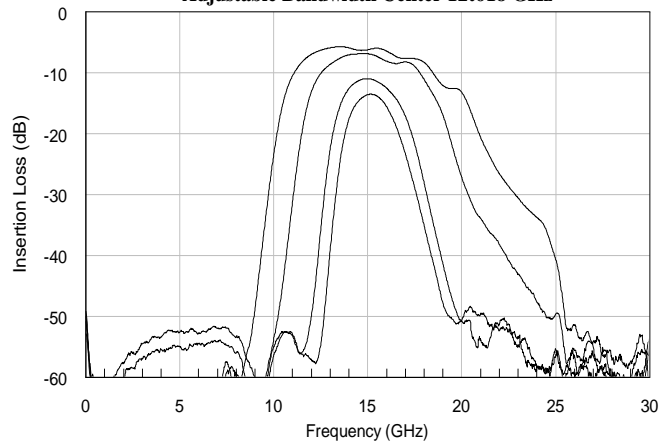

TYPICAL PERFORMANCE (CONTINUED)

*Note: Only some states shown for simplicity.

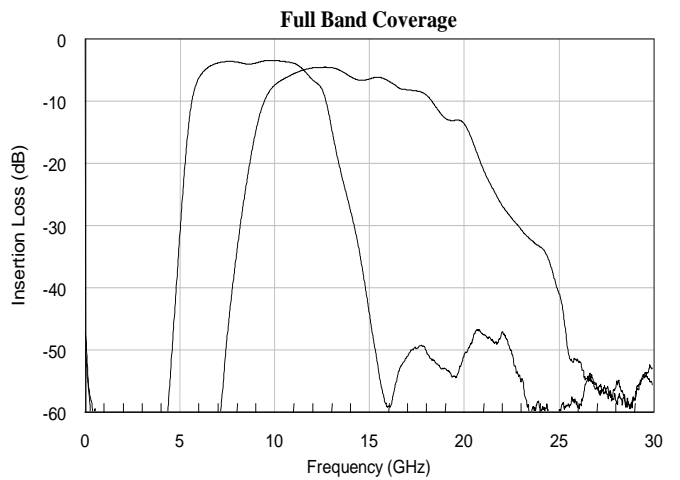
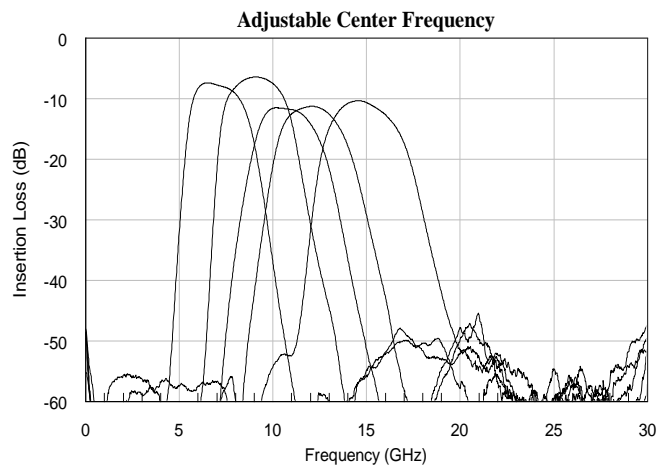
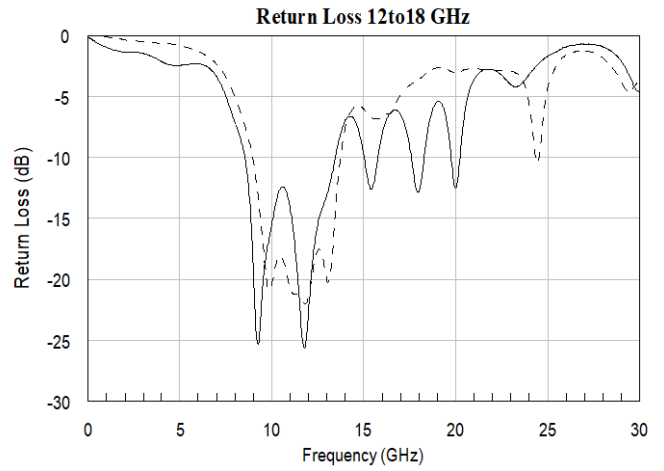
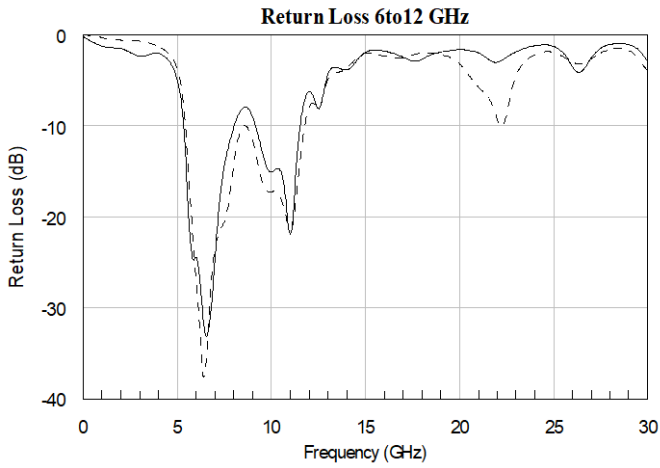

TYPICAL APPLICATION

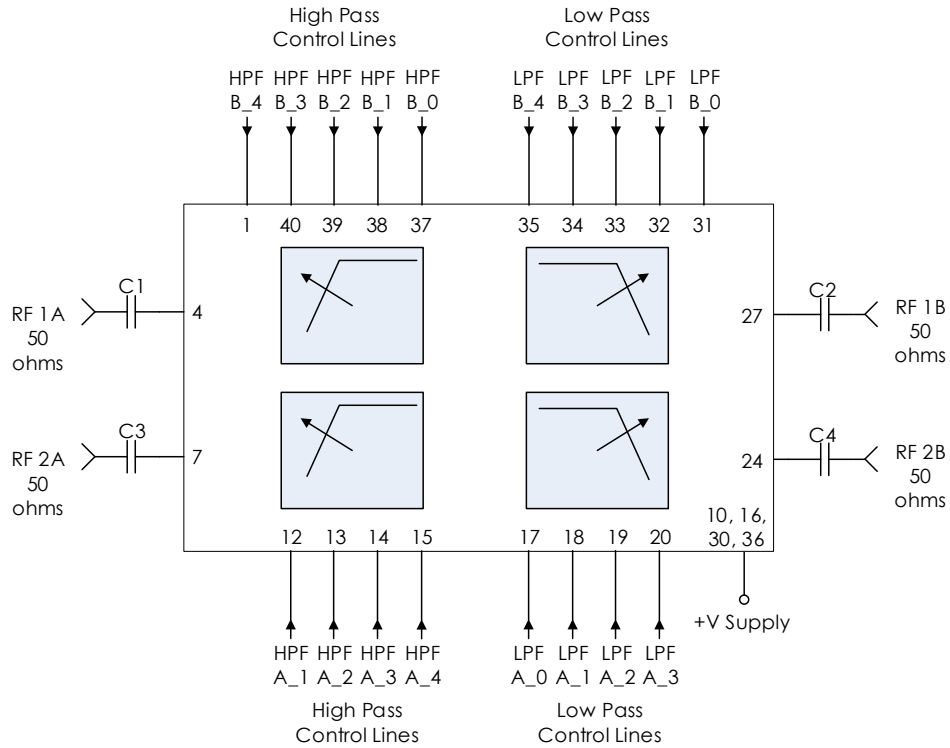

Recommended Component List (or Equivalent)

Part	Value	Part Number	Manufacturer
C1 - C4	0.1 μ F	0201BB104KW160	Passive Plus

Notes:

1. RF blocking capacitors should be high performance, low-loss, broadband capacitors for optimum performance.
2. VDD and control lines filtered internally providing high frequency isolation up to 50+ GHz.
 - a. No additional RC filtering required on control lines.
 - b. See AM35 datasheet for performance details.

EVALUATION PC BOARD

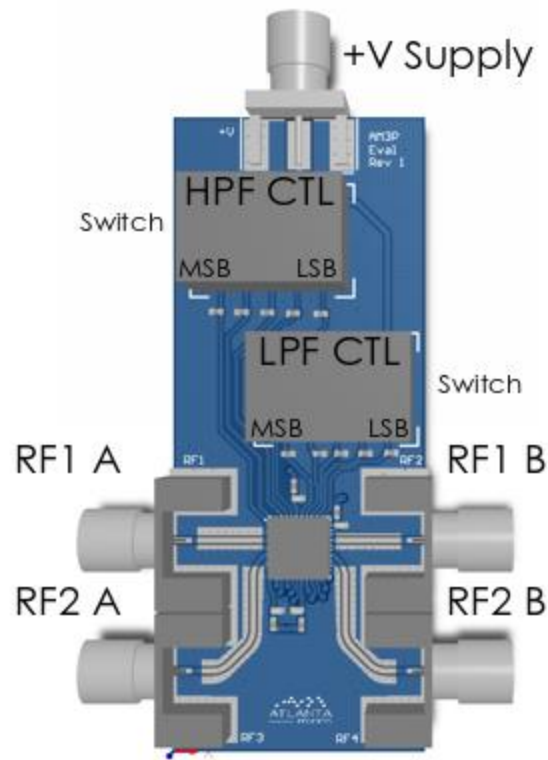

RELATED PARTS

Part Number	Description	
AM3060	0.32 GHz to 6.5 GHz	Switched Digitally Tunable BPF Bank
AM3064	1 GHz to 6.5 GHz	Digitally Tunable Bandpass Filter Bank
AM3065	6 GHz to 12 GHz	Digitally Tunable Bandpass Filter
AM3066	12 GHz to 26.5 GHz	Digitally Tunable Bandpass Filter Bank
AM3089	2 GHz to 18 GHz	Switched Analog Tunable BPF Bank
AM3134	2 GHz to 4.5 GHz	Analog Tunable Bandpass Filter Bank
AM3135	3.5 GHz to 9 GHz	Analog Tunable Bandpass Filter Bank
AM3136	8 GHz to 19 GHz	Analog Tunable Bandpass Filter Bank
AM35	100 MHz to 40 GHz	Power and Control EMI Filter Bank

COMPONENT COMPLIANCE INFORMATION

RoHS: Mercury Systems, Inc. hereby certifies that all products comply with the EC Directive 2011/65/EC on the Restriction of Hazardous Substances, commonly known as EU-RoHS 6 and 10. All products supplied by Mercury shall be compliant with the European Directive 2011/65/EC based on the following substance list.

Substance List	Allowable Maximum Concentration
Lead (Pb)	<1000 PPM (0.1% by weight)
Mercury (Hg)	<1000 PPM (0.1% by weight)
Cadmium (Cd)	<75 PPM (0.0075% by weight)
Hexavalent Chromium (CrVI)	<1000 PPM (0.1% by weight)
Polybrominated Biphenyls (PBB)	<1000 PPM (0.1% by weight)
Polybrominated Diphenyl ethers (PBDE)	<1000 PPM (0.1% by weight)
Decabromodiphenyl Deca BDE	<1000 PPM (0.1% by weight)
Bis (2-ethylhexyl) Phthalate (DEHP)	<1000 PPM (0.1% by weight)
Butyl Benzyl Phthalate (BBP)	<1000 PPM (0.1% by weight)
Dibutyl Phthalate (DBP)	<1000 PPM (0.1% by weight)
Diisobutyl Phthalate (DIBP)	<1000 PPM (0.1% by weight)

REACH: Mercury Systems, Inc. neither uses nor intentionally adds any of the substances considered to be a Substance of Very High Concern (SVHC) as defined by the EU Regulation (EC) No. 1907-2006 on Registration, Evaluation, Authorization, and Restriction of Chemicals (REACH).

Conflict Materials: Mercury does not knowingly use materials that are sourced from the Democratic Republic of Congo (DRC) or any other known conflict regions. Mercury’s supply chain is comprised of sources that are both environmentally and socially responsible. We periodically review this requirement with our vendors to ensure continued compliance.

Mercury takes its responsibility as a global partner seriously and will use due diligence within our supply chain to ensure all standards are met to the best of our knowledge.



Corporate Headquarters

50 Minuteman Road
 Andover, MA 01810 USA
 +1 978.967.1401 tel
 +1 866.627.6951 tel
 +1 978.256.3599 fax

International Headquarters

Mercury International

Avenue Eugène-Lance, 38
 PO Box 584
 CH-1212 Grand-Lancy 1
 Geneva, Switzerland
 +41 22 884 5100 tel

Learn more

Visit: mrcy.com

For pricing details, contact: MMICsales@mrcy.com

For technical details, contact: MMICsupport@mrcy.com



The Mercury Systems logo is a registered trademark of Mercury Systems, Inc. Other marks used herein may be trademarks or registered trademarks of their respective holders. Mercury products identified in this document conform with the specifications and standards described herein. Conformance to any such standards is based solely on Mercury’s internal processes and methods. The information contained in this document is subject to change at any time without notice.

