

# AM9012 – Tuner Mini-Module

## 2 MHz to 6 GHz Miniature Tuner Module

### Description

AM9012 is a fully integrated mini-module comprised of MMIC and MCM devices that provide a complete high dynamic range miniature tuner module covering the 2-MHz to 6 GHz frequency range. The superheterodyne tuner module is designed for high performance and low size, weight, and power (low SWaP) and is easily mounted to a host circuit board for use in multi-channel receiver applications. Sub-octave pre-selectors, pre-amplifiers, local oscillators, frequency converters, power and control line filtering, a temperature sensor and a control FPGA are included.

The analog IF output frequency is centered at 60 MHz with an 80 MHz bandwidth. Multiple tuner sets can be configured to work together for coherent operation and N-channel applications. Interfacing to the tuner is accomplished by simply providing an RF input, DC voltages, frequency reference, SPI control, and routing the IF output. Atlanta Micro provides a reference design for an A/D driver and A/D converter. Evaluation boards are available with either analog or 14-bit digital outputs.

### Features

- 2 MHz to 6 GHz Frequency Range
- 80-MHz Bandwidth
- 60-MHz IF Output Frequency
- Sub-Octave Preselection
- 13 dB Noise Figure, +3 dBm IIP3
- +3.3V DC Operation
- 4.0 W Power Consumption
- -40C to +85C Operation
- 1.44" x 2.33" x 0.26" (36.5 x 59.2 x 6.6 mm)



Penny shown for relative size

### Functional Diagram

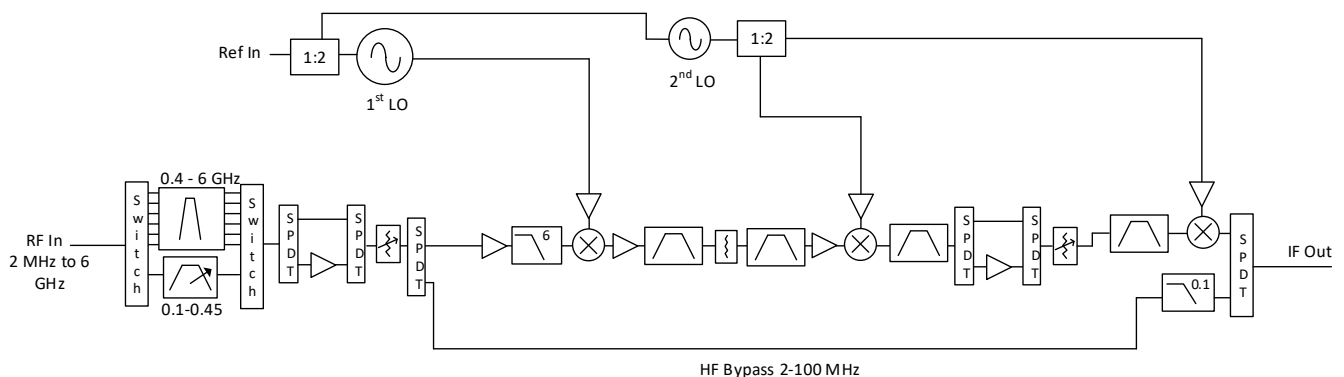

**Table of Contents**

<b>Description</b> .....	<b>1</b>	Timing Characteristics .....	<b>4</b>
<b>Features</b> .....	<b>1</b>	<b>Connector and Pin Definitions</b> .....	<b>5</b>
<b>Functional Diagram</b> .....	<b>1</b>	<b>Mechanical Details</b> .....	<b>6</b>
<b>Revision History</b> .....	<b>2</b>	Mechanical Drawing .....	6
<b>Specifications</b> .....	<b>3</b>	Recommended PCB Footprint .....	8
Absolute Maximum Ratings .....	3	<b>Evaluation PC Boards</b> .....	<b>9</b>
Handling Information .....	3	Single Channel Analog Eval Board .....	10
Recommended Operating Conditions ...	3	Dual-Channel Analog Eval Board .....	11
DC Electrical Characteristics .....	3	Single Channel Digital Eval Board .....	12
RF Performance <sup>1</sup> .....	4	Dual-Channel Digital Eval Board .....	13
2 to 100 MHz Bypass Performance .....	4		

**Revision History**

<b>Date</b>	<b>Revision Number</b>	<b>Notes</b>
January 10, 2020	1	Initial Release
March 6, 2020	2	General Corrections
April 20, 2020	3	Updated Datasheet Format
November 5, 2020	4	Added Eval Board Ordering Configurations and Information
November 6, 2020	5	Modified Part Description. Added more information to eval board configuration options.
November 30, 2020	6	Formatting changes, redundant information removed.

# AM9012 – Tuner Mini-Module

## 2 MHz to 6 GHz Miniature Tuner Module



### Specifications

#### Absolute Maximum Ratings

	Minimum	Maximum
RF Input Power		+17 dBm
Operating Temperature	-40 C	+85 C
Storage Temperature Range	-55 C	+150 C

**Note:** Any device operation beyond the Absolute Maximum Ratings may result in permanent damage to the device. The values listed in this table are extremes and do not imply functional operation of the device at these or any other conditions beyond what is listed under Recommended Operating Conditions. Any part subjected to conditions outside of what is recommended for an extended amount of time may suffer from reliability concerns.

#### Handling Information

	Minimum	Maximum
Storage Temperature Range (Recommended)	-50 C	+125 C



Atlanta Micro products are electrostatic sensitive.  
Follow safe handling practices to avoid damage

#### Recommended Operating Conditions

	Minimum	Typical	Maximum
Operating Case Temperature	-40 C		+85 C

#### DC Electrical Characteristics

(T = 25 °C unless otherwise specified)

Parameter	Testing Conditions	Minimum	Typical	Maximum
+3.3 VDC Supply		+3.2 V	+3.3 V	+3.5 V
+3.3 VDC Current			1.2 A	
Power Dissipated			4.0 W	
Logic Level Low		0 V		+0.8 V
Logic Level High		+2.0 V		+3.5 V

# AM9012 – Tuner Mini-Module

## 2 MHz to 6 GHz Miniature Tuner Module

### RF Performance<sup>1</sup>

(T = 25 °C unless otherwise specified)

Parameter	Notes	Minimum	Typical	Maximum
Frequency Range		2 MHz		6 GHz
Bandwidth			80 MHz	
Tune Frequency Range		60 MHz		5960 MHz
Frequency Reference	100 MHz External Reference Required	0 dBm		+10 dBm
Input IP3			+3 dBm	
Input IP2	(100 MHz – 6 GHz)		+50 dBm	
Noise Figure			13 dB	
Image Rejection			80 dB	
IF Rejection			80 dB	
LO Leakage			-100 dBm	
Gain			3 dB	
Gain Control / Attenuation Range			50 dB (1dB Steps)	
Sub-Octave Preselectors		100 MHz		6 GHz
Phase Noise	1 kHz Offset		-90 dBc/Hz	
	10 kHz Offset		-98 dBc/Hz	
	100 kHz Offset		-98 dBc/Hz	
	1 MHz Offset		-109 dBc/Hz	
	10 MHz Offset		-135 dBc/Hz	

**Note 1:** The gain from RF input to IF output is specified as post calibrated gain. Tuner gain from RF input to IF output is calibrated to 3 dB for optimum dynamic range. All RF performance in the table assumes this calibration. An external A/D driver and A/D is required for applications requiring digitization of the IF. Atlanta Micro can provide a proven reference design for those applications.

### 2 to 100 MHz Bypass Performance

(T = 25 °C unless otherwise specified)

Parameter	Notes	Minimum	Typical	Maximum
Frequency Range		2 MHz		100 MHz
Input IP3			+8 dBm	
Input IP2	(100 MHz – 6 GHz)		+50 dBm	
Noise Figure			12 dB	
Gain Control / Attenuation Range			24 dB (1dB Steps)	

### Timing Characteristics

Parameter	Minimum	Typical	Maximum
Sub-Octave Preselector Switching Speed			15 μs
Attenuation Switching Speed			10 μs
Tuning Speed		100 μs	

# AM9012 – Tuner Mini-Module

## 2 MHz to 6 GHz Miniature Tuner Module

### Connector and Pin Definitions

Host Board Connector Layout:

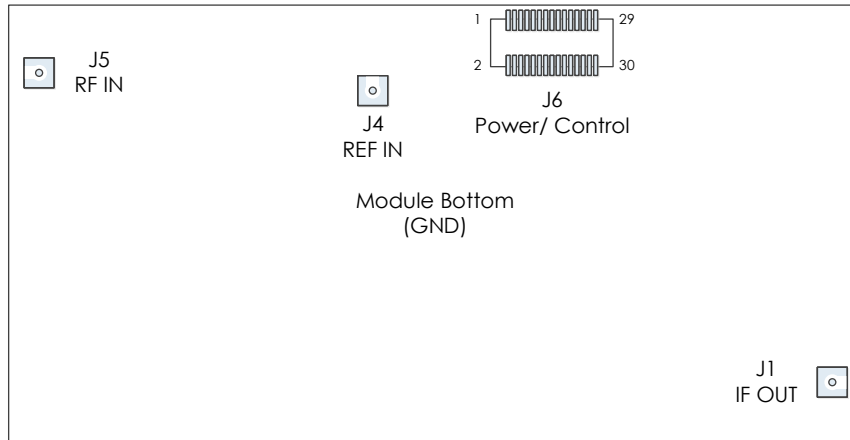

Connector	Name	Function
J1	IF OUT	60 MHz IF Output
J4	REF IN	100 MHz Reference Input Signal
J5	RF IN	0.002 to 6 GHz RF Input
J6	PWR/CTL	Power and Control Multi-pin Connector

J6 Pin #	J6 Pin Name	J6 Pin Function
1 - 6	+3.3 V	+3.3V DC Power Input
7	GND	Ground – Common
8	+3.3 V	+3.3V DC Power Input
9 – 14	GND	Ground – Common
15	JTAG_TDI	JTAG TDI
16	GND	Ground – Common
17	JTAG_TDO	JTAG TDO
18	JTAG_TCK	JTAG TCK
19	SCLK	SPI Bus Clock Input
20	JTAG_TMS	JTAG TMS
21	PROG_CSN	SPI Bus Select Line to Allow On-Board Programming Updates – Active Low
22	MISO	SPI Bus Data Output to Master Controller
23	CMD_CSN	SPI Bus Select Line for Sending Tuner Commands – Active Low
24	MOSI	SPI Bus Data Input from Master Controller
25	POP	Power On Pin – Active High. Low Logic Turns Off Tuner
26, 28	NC	Not Connected. Reserved for Future Use
27	RF_OVRD	Front-end RF Overload Indicator
29	LD	Lock Detect for Tuning LO. Logic Level High = Locked, Low = Unlocked
30	SYNC	Tuner LO Sync Line for Coherency

**\*Note:** Contact Atlanta Micro for an API that describes the software interface and commands necessary to control the tuner.

# AM9012 – Tuner Mini-Module

## 2 MHz to 6 GHz Miniature Tuner Module

### Mechanical Details

### Mechanical Drawing

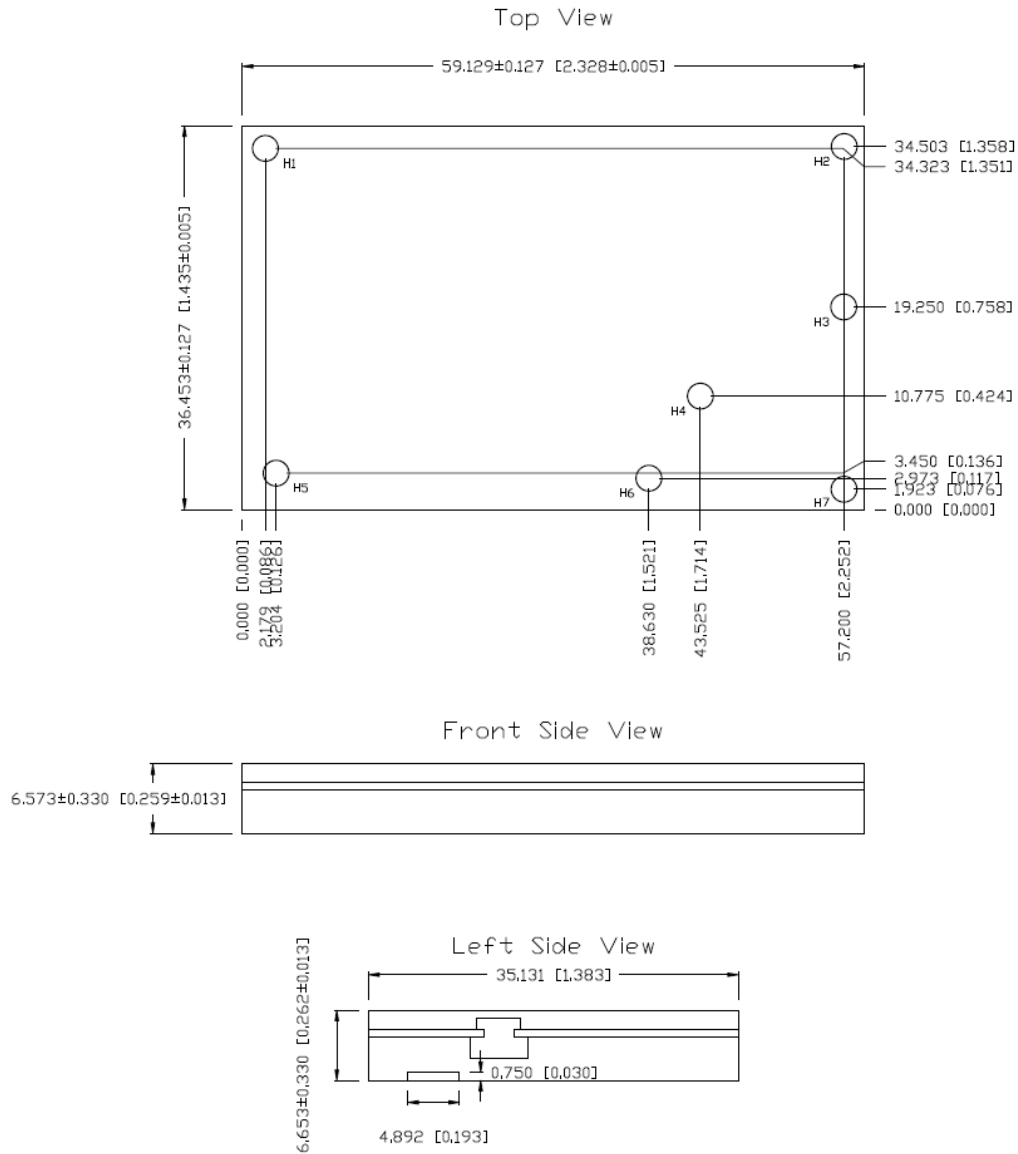

Optional End Launch RF Connectors for RF In and REF In. Contact factory for details.

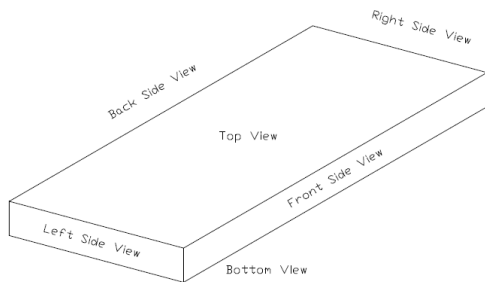

#### Notes

1. Dimension Units: millimeters [ inches ]
2. Holes H1 through H7 are through holes threaded where module meets PCB. Thread diameter is standard 2-56 thread from the top down.
3. All holes visible in Top View are countersunk 2-56 screw locations

# AM9012 – Tuner Mini-Module

## 2 MHz to 6 GHz Miniature Tuner Module

### Mechanical Details (continued)

### Mechanical Drawing (continued)

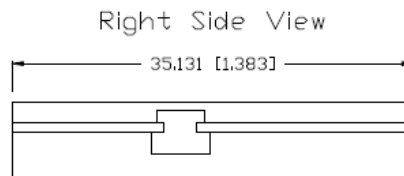
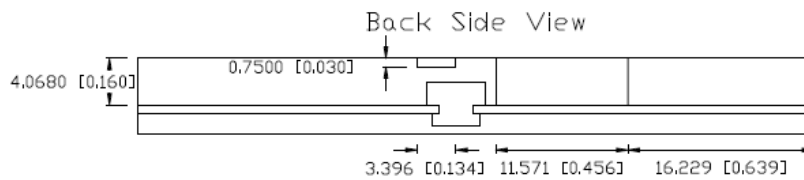
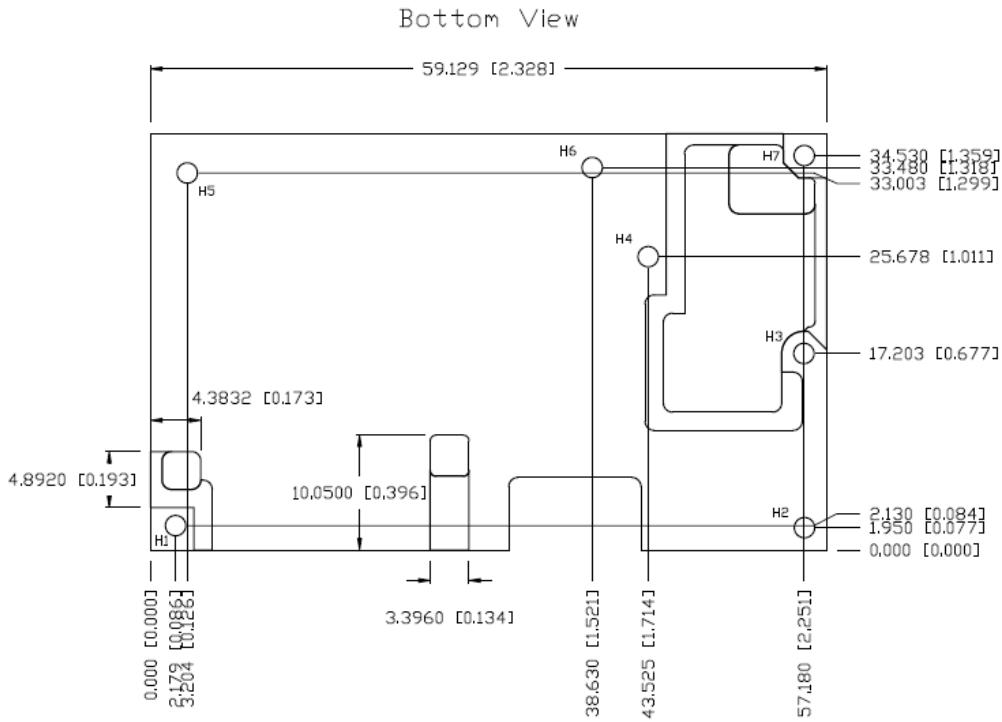

Optional End Launch RF Connector for IF Out. Contact factory for details.

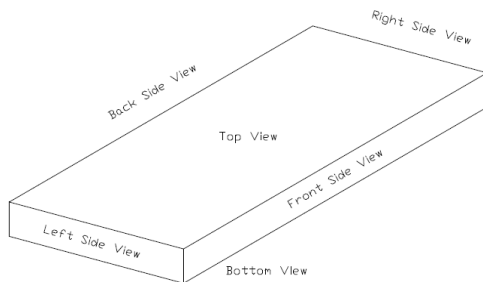

#### Notes

1. Dimension Units: millimeters [ inches ]
2. Holes H1 through H7 are through holes threaded where module meets PCB. Thread diameter is standard 2-56 thread from the top down.
3. All holes visible in Top View are countersunk 2-56 screw locations

# AM9012 – Tuner Mini-Module

## 2 MHz to 6 GHz Miniature Tuner Module

### Mechanical Details (continued)

#### Recommended PCB Footprint

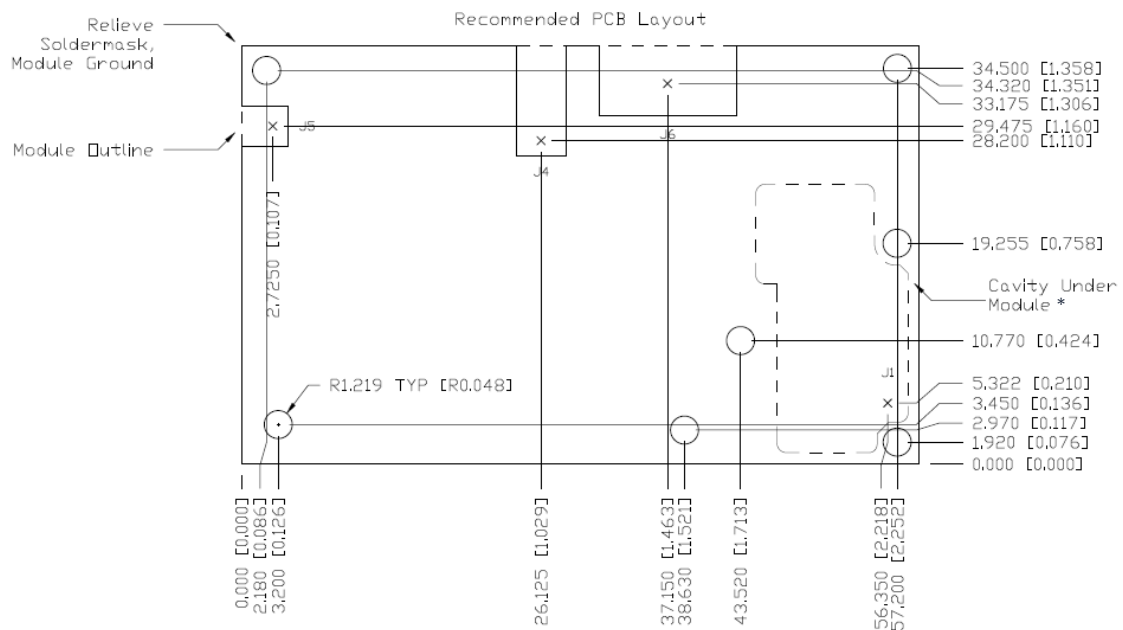
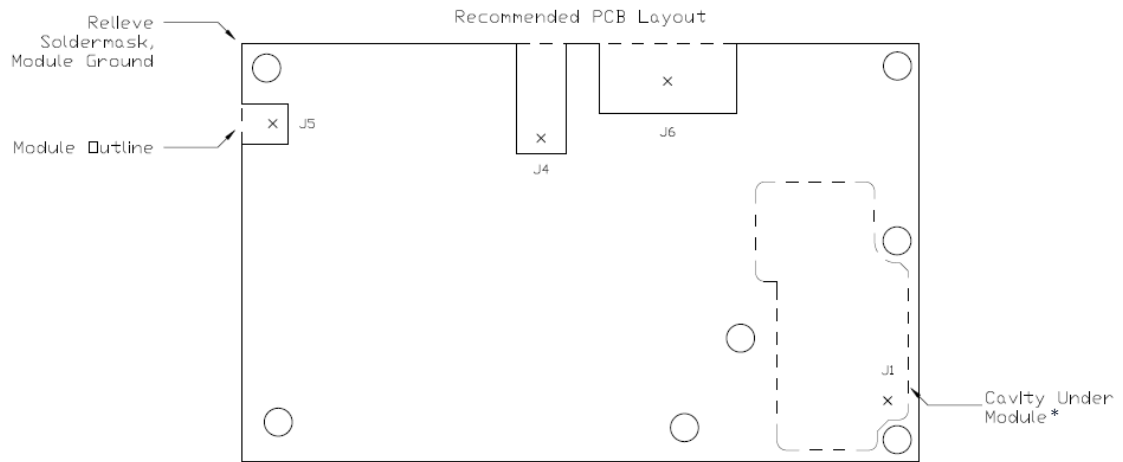

Required Host Board Connectors		
Designator	Part Number	Manufacturer
J1, J4, J5	55057-003J	Southwest Microwave
J6	DF12(4.0)-30DP-0.5V	Hirose Electric

#### Notes

1. Dimension Units: millimeters [ inches ]
2. X demarcates center of connectors, see recommended connectors

**\*Note:** Cavity provided for the placement of reference ADC design. Contact factory for details.



# AM9012 – Tuner Mini-Module

## 2 MHz to 6 GHz Miniature Tuner Module

### Evaluation PC Boards

There are 4 different evaluation board configurations with either analog or digital outputs. All evaluation boards come with Windows GUI control software and a user's guide. The evaluation board options are:

Description	Part Number
Single channel evaluation board, 60-MHz analog output	AM9012EVAL-A
Dual channel evaluation board, 60-MHz analog output	AM9012EVAL-2CH-A
Single channel evaluation board, 14-bit digital output, includes ADC driver amplifier	AM9012EVAL-D <sup>1</sup>
Dual channel evaluation board, 14-bit digital output, includes ADC driver amplifier	AM9012EVAL-2CH-D <sup>1</sup>

<sup>1</sup> The digital output evaluation boards are intended for use with the Analog Devices ADC Capture Card HSC-ADC-EVALCZ. The data capture card is not included. If using this card for data capture, only one channel can be measured at a time due to connector spacing limitations. The ADC Clock port accepts a 250 MSPS clock with a range of -4 dBm (-0.4 Vpp) to +15 dBm (3.6 Vpp). A 240 MSPS clock can also be used if a mathematically centered IF is desired.

# AM9012 – Tuner Mini-Module

## 2 MHz to 6 GHz Miniature Tuner Module

Single Channel Analog Eval Board  
(AM9012EVAL-A)

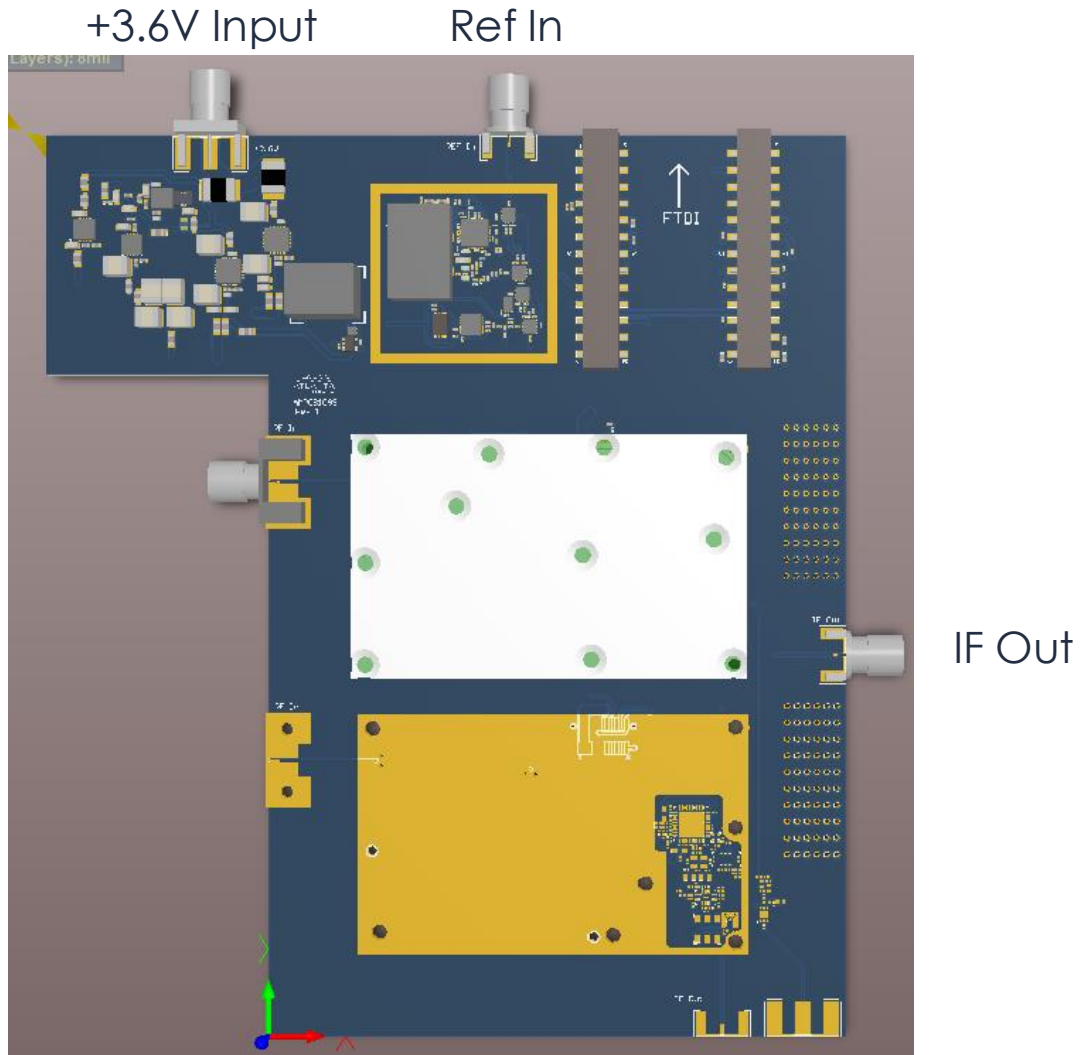

# AM9012 – Tuner Mini-Module

2 MHz to 6 GHz Miniature Tuner Module

## Dual-Channel Analog Eval Board

(AM9012EVAL-2CH-A)

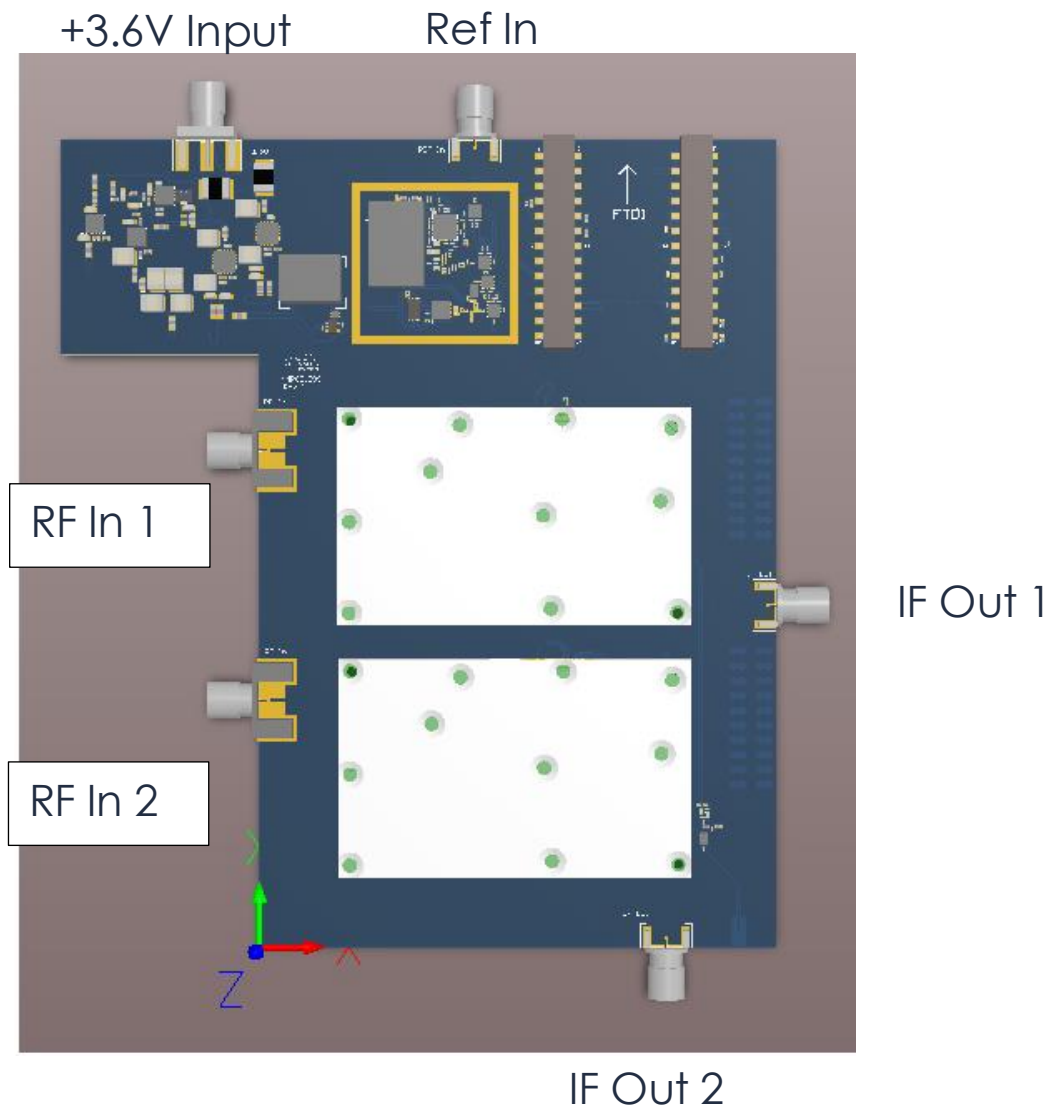

# AM9012 – Tuner Mini-Module

2 MHz to 6 GHz Miniature Tuner Module

## Single Channel Digital Eval Board

(AM9012EVAL-D)

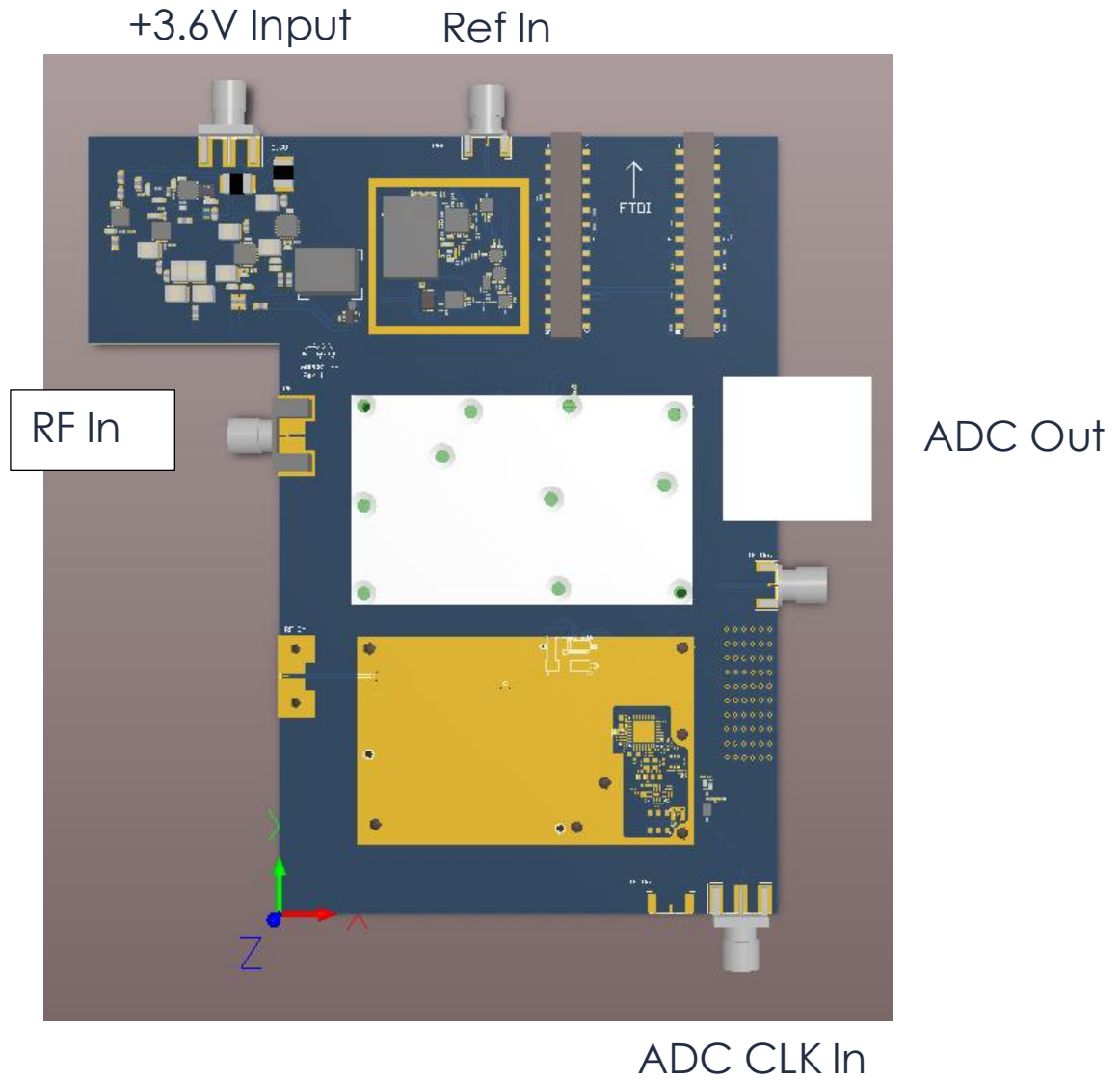

# AM9012 – Tuner Mini-Module

2 MHz to 6 GHz Miniature Tuner Module

## Dual-Channel Digital Eval Board

(AM9012EVAL-2CH-D)

