

AM3102 – Filter Bank

Digitally Tunable 0.33 to 1.2 GHz Bandpass

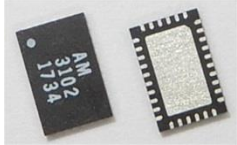

AM3102 is a miniature filter IC containing digitally tunable bandpass filters covering the 330 MHz to 1.2 GHz or 450 MHz to 1.5 GHz frequency range. Independent 4-bit digital control of the low-pass and high-pass corners provide control of both center frequency and bandwidth. AM3102 provides an excellent filtering solution for a receiver or transceiver requiring flexible center frequency and bandwidth, high dynamic range, and small size, weight, and power consumption.

Features

- Digitally Tunable Bandpass Filters
- Independent LP and HP control
- 4-bit Control, 3V or 5V Logic
- +3.3V to +5.0V Supply
- Integrated Control Line Filtering
- 2.5 dB Insertion Loss
- 4.0 x 6.0 mm QFN Package
- +40 dBm Input IP3
- -40C to +85C Operation

Functional Diagram

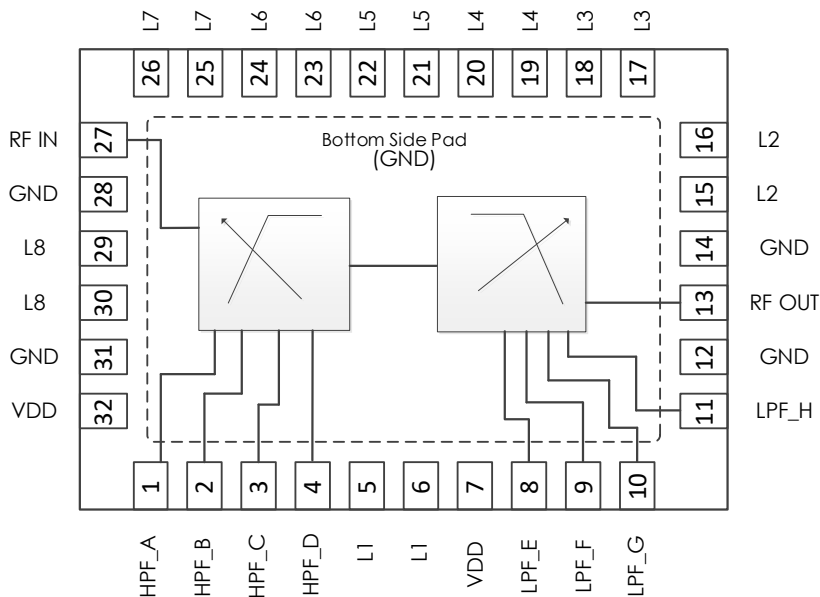

AM3102 – Filter Bank

Digitally Tunable 0.33 to 1.2 GHz Bandpass

Typical Performance

Note: Only some of the available states shown for simplicity.

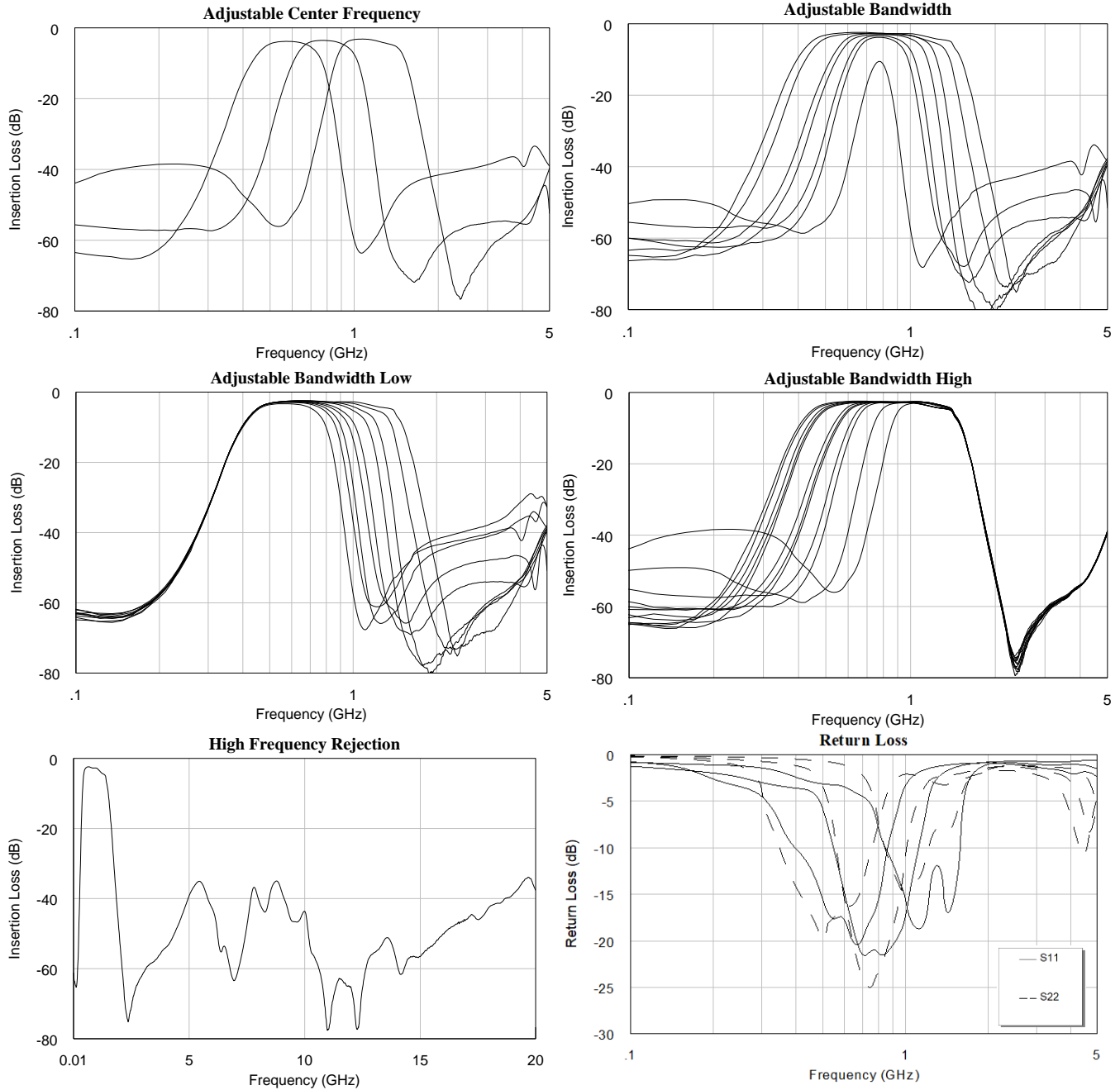

AM3102 – Filter Bank

Digitally Tunable 0.33 to 1.2 GHz Bandpass

Typical Applications Schematic 1: 330-1200 MHz

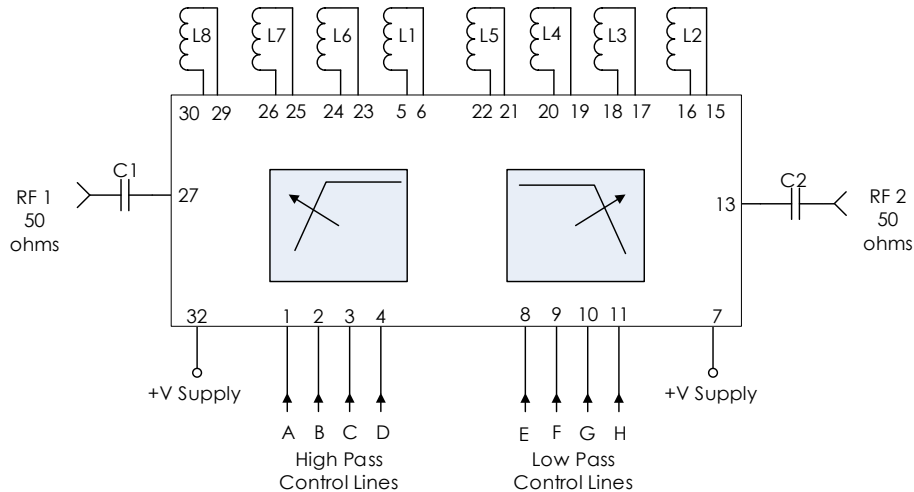

Recommended Component List (or equivalent):

Part	Value	Part Number	Manufacturer
C1, C2	0.1 uF	0402BB104KW160	Passives Plus
L1, L8	13 nH	0402HP-13NXGLW	Coilcraft
L2, L5	6.2 nH	0402HP-6N2XGLW	Coilcraft
L3, L4	6.8 nH	0402HP-6N8XGLW	Coilcraft
L6, L7	9.0 nH	0402HP-9N0XGLW	Coilcraft

Notes:

1. RF blocking capacitors should be high performance, low-loss, broadband capacitors for optimum performance.
2. VDD and control lines filtered internally providing high-frequency isolation to 20+ GHz.

AM3102 – Filter Bank

Digitally Tunable 0.33 to 1.2 GHz Bandpass

Typical Applications Schematic 2: 450-1500 MHz

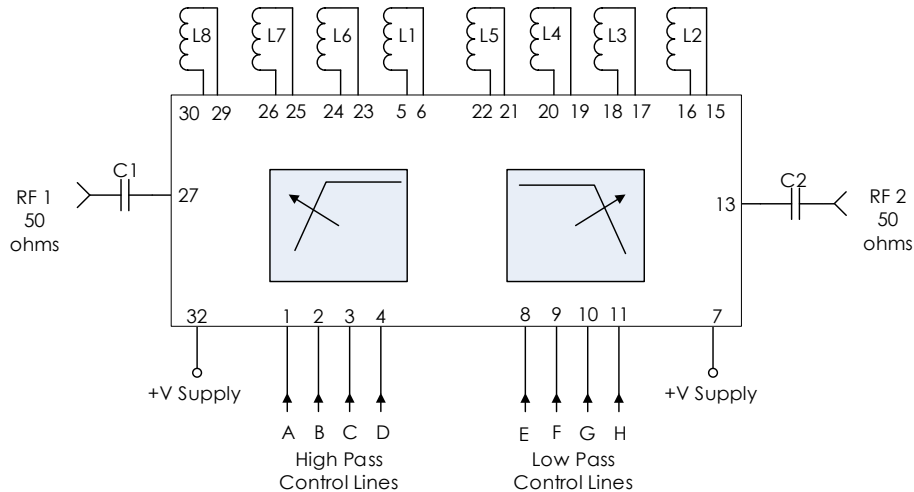

Recommended Component List (or equivalent):

Part	Value	Part Number	Manufacturer
C1, C2	0.1 uF	0402BB104KW160	Passives Plus
L1, L8	9.5 nH	0402HP-9N5XGLW	Coilcraft
L2, L5	2.2 nH	0402HP-2N2XJLW	Coilcraft
L3, L4	2.7 nH	0402HP-2N7XGLW	Coilcraft
L6, L7	5.6 nH	0402HP-5N6XGLW	Coilcraft

Notes:

- RF blocking capacitors should be high performance, low-loss, broadband capacitors for optimum performance.
- VDD and control lines filtered internally providing high-frequency isolation to 20+ GHz.

AM3102 – Filter Bank

Digitally Tunable 0.33 to 1.2 GHz Bandpass

Pin Definitions

Pin Number	Name	Function
1	HPF_A	High pass filter control A
2	HPF_B	High pass filter control B
3	HPF_C	High pass filter control C
4	HPF_D	High pass filter control D
5	L1A	External Inductor L1 Connection
6	L1B	External Inductor L1 Connection
7	VDD	DC Power Input
8	LPF_E	Low pass filter control E
9	LPF_F	Low pass filter control F
10	LPF_G	Low pass filter control G
11	LPF_H	Low pass filter control H
12	GND	Ground
13	RF OUT	RF output – 50 ohms – DC coupled. External DC blocking capacitor required.
14	GND	Ground
15	L2A	External Inductor L2 Connection
16	L2B	External Inductor L2 Connection
17	L3A	External Inductor L3 Connection
18	L3B	External Inductor L3 Connection
19	L4A	External Inductor L4 Connection
20	L4B	External Inductor L4 Connection
21	L5A	External Inductor L5 Connection
22	L5B	External Inductor L5 Connection
23	L6A	External Inductor L6 Connection
24	L6B	External Inductor L6 Connection
25	L7A	External Inductor L7 Connection
26	L7B	External Inductor L7 Connection
27	RF IN	RF Input – 50 ohms – DC coupled. External DC blocking capacitor required.
28	GND	Ground
29	L8A	External Inductor L8 Connection
30	L8B	External Inductor L8 Connection
31	GND	Ground
32	VDD	DC Power Input

AM3102 – Filter Bank

Digitally Tunable 0.33 to 1.2 GHz Bandpass

Specifications

Specifications	Minimum	Typical	Maximum
Frequency Range	330 MHz 450 MHz		1.2 GHz 1.5 GHz
Insertion Loss		2.4dB	
Input IP3		+40dBm	
RF Input Level			+27dBm
Switching Speed			1μs
Logic Level Low	-0.1V		+0.5V
Logic Level High	+2.0V		+5.0V
Package Size		4.0 x 6.0 x 0.9 mm	
DC Supply Voltage	+3.1V		+5.2V
DC Supply Current		2mA	
Power Consumption		10mW	
Operating Temperature	-40 C		+85 C
Storage Temperature	-50 C		+125 C

AM3102 – Filter Bank

Digitally Tunable 0.33 to 1.2 GHz Bandpass

Control Table

High Pass Control Lines				Typical Cutoff Frequency (MHz)
D	C	B	A	
L	L	L	L	330
L	L	L	H	332
L	L	H	L	338
L	L	H	H	341
L	H	L	L	354
L	H	L	H	359
L	H	H	L	373
L	H	H	H	381
H	L	L	L	443
H	L	L	H	448
H	L	H	L	463
H	L	H	H	473
H	H	L	L	508
H	H	L	H	531
H	H	H	L	618
H	H	H	H	717

Low Pass Control Lines				Typical Cutoff Frequency (MHz)
H	G	F	E	
L	L	L	L	493
L	L	L	H	503
L	L	H	L	518
L	L	H	H	530
L	H	L	L	552
L	H	L	H	567
L	H	H	L	587
L	H	H	H	604
H	L	L	L	661
H	L	L	H	690
H	L	H	L	731
H	L	H	H	767
H	H	L	L	850
H	H	L	H	915
H	H	H	L	1032
H	H	H	H	1200

AM3102 – Filter Bank

Digitally Tunable 0.33 to 1.2 GHz Bandpass

Package Details

